

www.hawke-hts.com

HTS systems available worldwide through our local suppliers network and sales points.

Prompt deliveries from our strategic logistic centres and local stocks available all around the world.



Hawke Transit System

HAWKE TRANSIT SYSTEM-HTS

HEAD OFFICE
Paseo del Niño 4, nave B-2
39300 Torrelavega. Spain
Tel.: +34 942 89 00 52
Fax: +34 942 88 30 58
sales@hawke-hts.com

U.K. SALES OFFICE
HTS Logistic centre P.O. Box 271
WILMSLOW
SK9 3WS United Kingdom
Tel.: +44(0) 1625 252162
Fax: +44(0) 1625 251062
salesuk@hawke-hts.com

HAWKE TRANSIT ASIA PTE LTD.
No.18 Boon Lay Way
#02-143 Tradehub 21
Singapore 609966
Tel: +65 66862242
Fax: +65 66862252
salesasia@hawke-hts.com

HAWKE TRANSIT SYSTEM INDIA
Signet International
15 A, Kalidas Road, Dehradun 248001
Uttarakhand - India
Tel: +91 135 2743571
Fax: +91 135 2743572
a.bose@hawke-hts.com

Hawke Transit System



EMC System
avoid the risk

avoid the risk



EMC Hawke Transit System

Essential to ensure the integrity of computer and military communications. Specially prepared to eliminate stray air bourn and cable screen signals/noise, apart from being certified as a fire, water and gas barrier.

Stray signal/noise cannot pass through the conductive EMC and pass to earth. Tolerant and filler blocks have a cable range of 3mm to 100mm and are coated with a high conductive material. Copper tape provides high conductive path from cable screen to earth. Frame zinc plated or stainless steel to allow conductivity from blocks to earth.

Simple preparation of cable and assembly of system without modification of insert blocks onsite.



ATEX PRODUCTS

- HTS Products are also available in ATEX versión.
- Approved to: EN standard regulation with EC-Type Examination Certificate
- Approved ATEX Certification number: LOM 08ATEX 2048X and LOM 08ATEX 3047U
- If required, material ATEX must be specified in the P.O.
- ATEX certificates are only valid when they are used in conjunction with the other Hawke MCT Eex frames and components

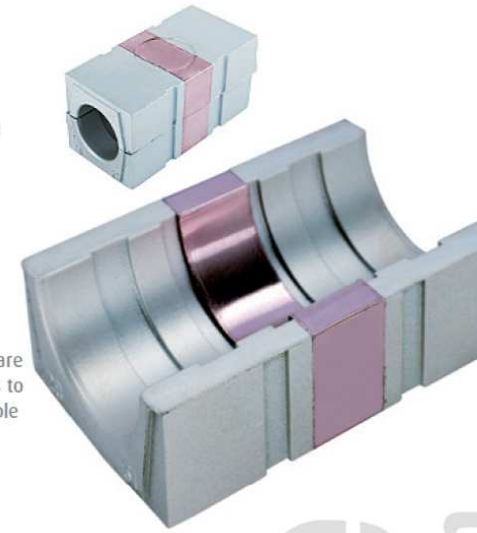

Tolerant block size range

Made of zero halogen, intumescent elastomeric polymer. Produced in modular form to accommodate a compact range of block sizes. They

have five sealing faces that are displaced by the sealing process to give a tolerance of to 4mm for cable diameters.

Case studies

- Battleships
- Frigates F-100 and F-310
- Amphibious Ships
- LHD and LCM
- Submarines
- Combat support ships
- Joint Support Ships (JSS)
- High Speed Attack Craft

Major navies using Hawke Transit System

ROYAL AUSTRALIAN NAVY 	ROYAL BRITISH NAVY 
ROYAL NORWEGIAN NAVY 	BOLIVARIAN VENEZUELAN NAVY 
ROYAL NETHERLANDS NAVY 	UNITED STATES NAVY 
ROYAL SPANISH NAVY 	INDIAN NAVY 

Hawke Transit System

Hawke Transit System

Unique cable transit system ideal for navy

The HTS cable/pipe tolerant blocks have been designed with a degree of flexibility to accommodate variances in cable diameters. With a small number of blocks it is possible accommodate the full range of standard cable sizes. This allows a much simpler and faster installation and inspection procedures than offered by other systems and fewer inventories.

